

MAXIM

MAX4273 Evaluation Kit

Evaluates: MAX4273

General Description

The MAX4273 evaluation kit (EV kit) is a fully assembled and tested surface-mount hot-swap controller circuit board that provides current-limiting and DualSpeed/Bi-Level™ fault protection. The circuit uses a MAX4273 IC in a 16-pin QSOP package and is configured for a +2.7V to +13.2V input voltage range.

The MAX4273 controls the N-channel MOSFET and provides current regulation during startup. Several configurations allow the MAX4273 IC's unique current regulation architecture to be tailored to the application. The current-limiting and short-circuit protection features are configurable and demonstrate the various features provided by the MAX4273 IC.

The EV kit features a power-on reset (POR) circuit. Several configurations for autoretry, glitch filters, auxiliary VCC power, and gate drive speed are provided. The EV kit can also be reconfigured to emulate the MAX4271 and MAX4272 hot-swap controllers.

DualSpeed/BiLevel is a trademark of Maxim Integrated Products.

Features

- ◆ **+2.7V to +13.2V Input Range**
- ◆ **Output Configured for +5V (Configurable from +2.7V to +13.2V)**
- ◆ **Up to 10A Capability (as Configured)**
- ◆ **Demonstrates Unique Current-Regulation Architecture**
- ◆ **Auxiliary VCC Feature**
- ◆ **Power-On Reset Circuit**
- ◆ **Configurable Autoretry**
- ◆ **Adjustable N-Channel MOSFET Gate Charging Time**
- ◆ **Configurable Glitch Filters**
- ◆ **Also Emulates MAX4271 and MAX4272 Hot-Swap Controllers**
- ◆ **Surface-Mount Components**
- ◆ **Fully Assembled and Tested**

Ordering Information

PART	TEMP. RANGE	IC PACKAGE
MAX4273EVKIT	0°C to +70°C	16 QSOP

Component List

DESIGNATION	QTY	DESCRIPTION
C1, C12	2	1.0μF, 16V X5R ceramic capacitors (0805) Taiyo Yuden EMK212BJ105KG
C2, C3	2	0.1μF, 50V X7R ceramic capacitors (0805) Taiyo Yuden UMK212BJ104KG
C4	1	3300pF, 50V ceramic capacitor (0603) Taiyo Yuden UMK107BJ332KZ
C5	1	0.068μF, 50V X7R ceramic capacitor (0805) Taiyo Yuden UMK212BJ683KG
C6	1	1000μF, 16V OS-CON capacitor (H case) Sanyo 16SA1000M

DESIGNATION	QTY	DESCRIPTION
C7, C8	0	Not installed (F12 case) Sanyo 16SV220M recommended
C9	1	0.22μF, 35V X7R ceramic capacitor (0805) Taiyo Yuden GMK212BJ224KG
C10, C13	2	0.01μF, 50V X7R ceramic capacitors (0603) Taiyo Yuden UMK107 B103KZ
C11	0	Not installed, (H case) Sanyo 16SA1000M recommended
C14	1	330pF, 50V X7R ceramic capacitor (0603) Murata GRM39X7R331K050

MAX4273 Evaluation Kit

Component List (continued)

DESIGNATION	QTY	DESCRIPTION
R1, R4, R5	3	1M Ω \pm 5% resistors (0805)
R2, R7	2	10k Ω \pm 1% resistors (0805)
R3	1	0.004 Ω \pm 1% 1W power resistor Dale WSL2512 0.004 Ω \pm 1% R86 IRC OARS-1-4m Ω
R6	1	64.9k Ω \pm 1% resistor (0805)
R8	0	Not installed, resistor (0805)
N1	1	30V, 100A N-channel MOSFET (D ² PAK) Fairchild FDB7030L or International Rectifier IRL3803S
J1–J4	4	Uninsulated banana jacks Mouser 530-108-0740-1
JU1, JU4, JU5, JU7	4	2-pin headers
JU2, JU6	2	3-pin headers
JU3	1	4-pin header
None	7	Shunts (JU1–JU7)
None	4	Rubber bumpers 3M SJ-5003
U1	1	MAX4273EEE (16-pin QSOP)
None	1	MAX4273 data sheet
None	1	MAX4273 EV kit data sheet

Component Suppliers

SUPPLIER	PHONE	FAX
Dale/Vishay	402-564-3131	402-563-6418
Fairchild	408-822-2000	408-822-2102
International Rectifier	310-322-3331	310-322-3332
IRC	512-992-7900	512-992-3377
Murata	814-237-1431	814-238-0490
Sanyo USA	619-661-6835	619-661-1055
Taiyo Yuden	408-573-4150	408-573-4159

Note: Please indicate that you are using the MAX4273 when contacting these component suppliers.

Quick Start

The MAX4273 EV kit is fully assembled and tested. Follow these steps to verify board operation. **Do not turn on the power supply until all connections are completed.**

MAX4273 Configuration +5V, 10A Output

- 1) Verify that shunts are on jumpers JU4 (CSPD), JU5 (AUXVCC), and JU7 (CTON).
- 2) Verify that jumper JU1 (ON) does not have a shunt installed.
- 3) Verify that jumper JU3 (RTH) has a shunt installed on pins 1 and 3.
- 4) Verify that a shunt is installed on pins 2 and 3 of jumper JU2 (CTIM) and on pins 1 and 2 of jumper JU6 (GATE).
- 5) **Utilizing very short 10A rated banana leads (<6in long)**, connect the +5VDC power supply to the V_{IN} pad. **Utilizing very short 10A rated banana leads (<6in long)**, connect the supply ground to the GND pad.
- 6) Connect a voltmeter to the V_{OUT} and GND pads.
- 7) Turn on the power supply and verify that the voltage at V_{OUT} is +5V.
- 8) Test point 1 (TP1) is provided to observe the MOSFET gate voltage with an oscilloscope.

Note: The banana leads connecting the power supply and the load to the EV kit must be very short (<6in long) and rated for at least 10A of current.

Detailed Description

The MAX4273 EV kit is a hot-swap controller circuit board that provides configurable current-limiting and bilevel fault protection for the output. The bilevel fault protection provides low-amplitude current-overload protection and protection from instantaneous faults such as a short-circuit condition. The circuit uses a MAX4273 IC, configured for an input range of +5V to +13.2V, and can pass up to 10A of current to the output. The input feeds a current-sense resistor and N-channel MOSFET, which controls current between the input and output of the EV kit.

The MAX4273 IC controls the N-channel MOSFET in conjunction with gate capacitors, which provide current regulation during startup and bilevel fault protection during steady-state operation. A jumper to capacitors and a resistor allow control of the MOSFET gate charging time. A test point is provided to verify the gate signal with an oscilloscope.

The MAX4273 EV kit features a POR that will trip when the input voltage drops by 10%. The autoretry, glitch filters, and auxiliary V_{CC} power have jumpers that allow easy configuration changes. Through proper selection of jumpers, the EV kit can emulate the MAX4271 and

MAX4273 Evaluation Kit

Evaluates: MAX4273

MAX4272 hot-swap controllers. PC board pads for extra output capacitors are provided on the EV kit.

Jumper Selection

Tables 1–7 display the functions provided by the MAX4273 EV kit.

MOSFET Enable and Fault Resetting

The MAX4273 EV kit features a combination shutdown/unlatch fault mode. The 2-pin jumper, JU1, selects the shutdown/unlatch mode for the MAX4273 EV kit. Table 1 lists the selectable jumper options.

Table 1. Jumper JU1 Functions

SHUNT LOCATION	ON PIN	EV KIT OUTPUT
Installed	ON pin pulled low	Disable MOSFET N1, unlatch fault
None	ON pin pulled high	Enable MOSFET N1, normal operation*

*If JU2 is set for latched mode, the device will be latched following a fault condition.

ON Pin and Latched and Retry Modes

The MAX4273 EV kit features a jumper to select latched mode or retry timer settings. The 3-pin jumper, JU2, selects the retry time for the MAX4273 IC. Table 2 lists the various jumper options.

Table 2. Jumper JU2 Functions

SHUNT LOCATION	CTIM PIN	EV KIT MODE
1, 2	Connected to VIN	Latched mode
2, 3	Connected to C3 and C13	Retry mode, 1.1s
None	Connected to C13	Retry mode, 100ms

Fast Comparator and Current Regulation

The MAX4273 EV kit features a jumper to enable or disable the fast comparator and to set the threshold level. The 3-pin jumper, JU3, selects the threshold level. Table 3 lists the jumper options.

Table 3. Jumper JU3 Functions

SHUNT LOCATION	RTH PIN	FAST COMPARATOR
1, 4	Connected to VIN	Fast comparator and current regulation disabled
1, 2	Connected to GND	200mV internal threshold
1, 3	Connected to R2	100mV threshold

Slow Comparator Response Time

The MAX4273 EV kit features two choices for the slow comparator response time. The 2-pin jumper, JU4, is used to select other speed settings. Table 4 lists the selectable jumper options.

Table 4. Jumper JU4 Functions

SHUNT LOCATION	CSPD PIN	SLOW COMPARATOR
Installed	Connected to C2 and C10	22ms slow comparator response time
None	Connected to C10	2ms slow comparator response time

Auxiliary VCC Power

The MAX4273 EV kit features an auxiliary supply for VCC. A capacitor on the auxiliary supply pin provides energy to the IC during a short-circuit fault condition, which could cause the main system power supply to collapse. The 2-pin jumper, JU5, enables or disables the feature by connecting or disconnecting the capacitor. Table 5 lists the selectable jumper options.

Table 5. Jumper JU5 Functions

SHUNT LOCATION	AUXVCC PIN	EV KIT MODE
Installed	AUXVCC pin connected to C1	Auxiliary supply connected
None	AUXVCC pin floating	Auxiliary supply disconnected

MAX4273 Evaluation Kit

MOSFET Charging Time

The MAX4273 EV kit features several choices for controlling the charging time of the N-channel MOSFET. Jumper JU6 selects the charge time for the MOSFET. Table 6 lists the selectable jumper options. The charging time reflects output voltage close to the final value.

Table 6. Jumper JU6 Functions

SHUNT LOCATION	GATE PIN	MOSFET CHARGE TIME
1, 2	Connected to C5	7ms gate charging time, fast discharge possible
2, 3	Connected to C9	22ms gate charging time
None	Connected to N1 gate terminal only	215 μ s gate charging time

Startup Timer Setting

The MAX4273 EV kit features two choices for the longest time allowed to completely turn on the MOSFET. Jumper JU7 selects the time and Table 7 lists the selectable jumper options.

Table 7. Jumper JU7 Functions

SHUNT LOCATION	CTON PIN	EV KIT MODE
Installed	Connected to C4 and C14	1.1ms T_{ON} setting
None	Connected to C14	103 μ s T_{ON} setting

Control Modes

MOSFET Gate Control

The MAX4273 EV kit features several options to control the MOSFET gate charging time. Table 6 lists the various jumper selectable options. Resistor R8 is also provided to prevent MOSFET oscillations when a capacitor to ground is used. The shorted trace across resistor R8 must be cut open prior to using it. Refer to the MAX4273 data sheet for information on selecting the value of resistor R8. Test point TP1 is provided to observe the gate voltage with an oscilloscope.

Fault Resetting

The MAX4273 EV kit features a jumper (JU1) to latch/unlatch faults and enable/disable the output MOS-

FET. See Table 1 for proper jumper settings. An external controller can be utilized to control the ON pin of the MAX4273. Refer to the MAX4273 data sheet for additional functions of the ON pin when toggling it.

Caution: Do not connect an external microcontroller to the ON pad while a shunt is installed on jumper JU1. The shunt provides a short from ON to GND and may damage the external controller.

+3V, 10A Evaluation

The MAX4273 EV kit can evaluate a hot-swap controller operating at +3V and provide up to 10A of current at the output. Replace POR resistor R6 with a 34.8k Ω resistor to obtain a trip level of 2.7V at V_{IN} . For other current levels, resistor R3 must be replaced with a resistor selected for the desired current. If a different fast comparator threshold is desired, resistor R2 must also be replaced. Refer to the MAX4273 data sheet for information on selecting resistors R2 and R3.

+12V, 2A Evaluation

The MAX4273 EV kit can evaluate a hot-swap controller operating at +12V and provide up to 2A of current at the output. Replace POR resistor R6 with a 169k Ω resistor to obtain a trip level of 10.8V at V_{IN} . Resistor R3 must be replaced with a resistor selected for the 2A load. If a different fast comparator threshold is desired, resistor R2 must also be replaced. Refer to the MAX4273 data sheet for information on selecting resistors R2 and R3.

MAX4271/MAX4272 Emulation

The MAX4273 EV kit can emulate the MAX4271 and MAX4272 IC features. The EV kit uses a MAX4273 IC and properly set jumpers to emulate a MAX4271 or MAX4272 design. See Table 8 or 9 to emulate a MAX4271 or MAX4272 design, respectively. Refer to the MAX4273 data sheet for a description of specific pin functions of the MAX4273 IC and its associated external components. **Caution: Only one emulation mode can be evaluated at a time.**

MAX4273 Evaluation Kit

Evaluates: MAX4273

Table 8. Emulating a MAX4271 Design

JUMPER	SHUNT LOCATION	MAX4273 PIN	MAX4271 EV KIT MODE EMULATED
JU1	Installed	ON	Disable MOSFET N1, unlatch fault
JU1	None	ON	Enable MOSFET N1, normal operation
JU2	1, 2	CTIM	No retry, latched mode
JU3	1, 2	RTH	200mV internal fast comparator threshold (50A)
JU4	Installed	CSPD	22ms slow comparator speed setting
JU4	None	CSPD	2ms slow comparator speed setting
JU5	None	AUXVCC	AUXVCC disabled
JU6	2, 3	GATE	22ms MOSFET gate charging time
JU6	None	GATE	215μs MOSFET gate charging time
JU7	Installed	CTON	1.1ms startup timer T _{ON} setting*
JU7	None	CTON	103μs startup timer T _{ON} setting*
JU8	Cut open the trace shorting JU8	LLMON	No line-load monitor feature when emulating a MAX4271**

*The MAX4273 CTON pin is providing the CTIM functionality of the MAX4271.

**When demonstrating a MAX4273 EV kit, the PC board trace shorting jumper JU8 must be reinstalled with a wire jumper.

Table 9. Emulating a MAX4272 Design

JUMPER	SHUNT LOCATION	MAX4273 PIN	MAX4272 EV KIT MODE EMULATED
JU1	Installed	ON	Disable MOSFET N1
JU1	None	ON	Enable MOSFET N1
JU2	2, 3	CTIM	Retry mode, 1.1s retry time
JU2	None	CTIM	Retry mode, 100ms retry time
JU3	1, 2	RTH	200mV internal fast comparator threshold (50A)
JU4	Installed	CSPD	22ms slow comparator speed setting
JU4	None	CSPD	2ms slow comparator speed setting
JU5	None	AUXVCC	AUXVCC disabled
JU6	2, 3	GATE	22ms MOSFET gate charging time
JU6	None	GATE	215μs MOSFET gate charging time
JU7	Installed	CTON	1.1ms startup timer T _{ON} setting*, default
JU7	None	CTON	103μs startup timer T _{ON} setting*, default
JU8	Cut open the trace shorting JU8	LLMON	No line-load monitor feature when emulating a MAX4272 **

*The total capacitance on the CTON pin (C4, C14) must equal the total capacitance on the CTIM pin. This will emulate the shared functionality of a MAX4272 CTIM pin. Refer to the MAX4271/MAX4272/MAX4273 data sheet Table 4 or the Pin Description for more details on CTIM and CTON.

**When demonstrating a MAX4273 EV kit, the PC board trace shorting jumper JU8 must be reinstalled with a wire jumper.

MAX4273 Evaluation Kit

Evaluates: MAX4273

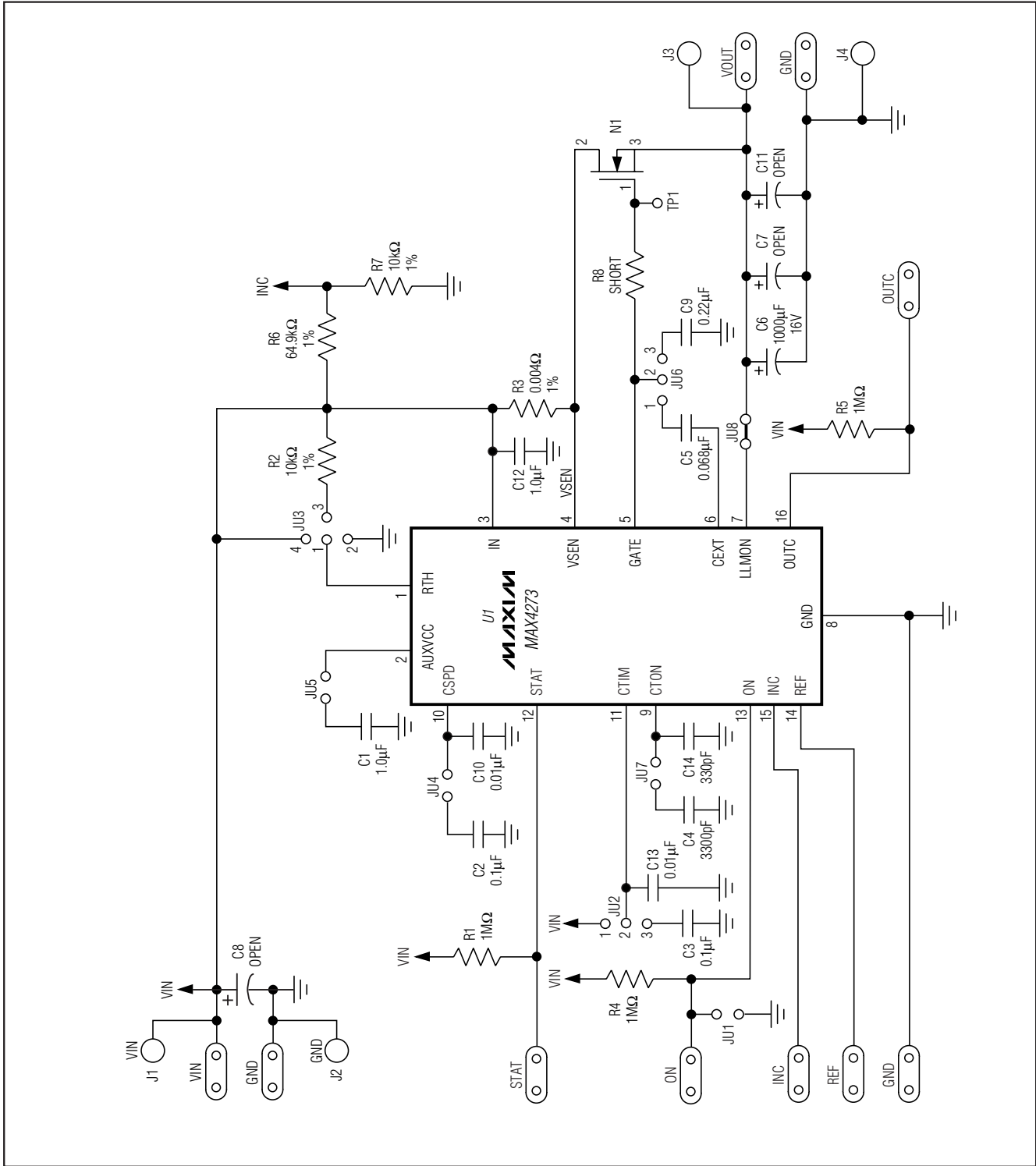

Figure 1. MAX4273 EV Kit Schematic

MAX4273 Evaluation Kit

Evaluates: MAX4273

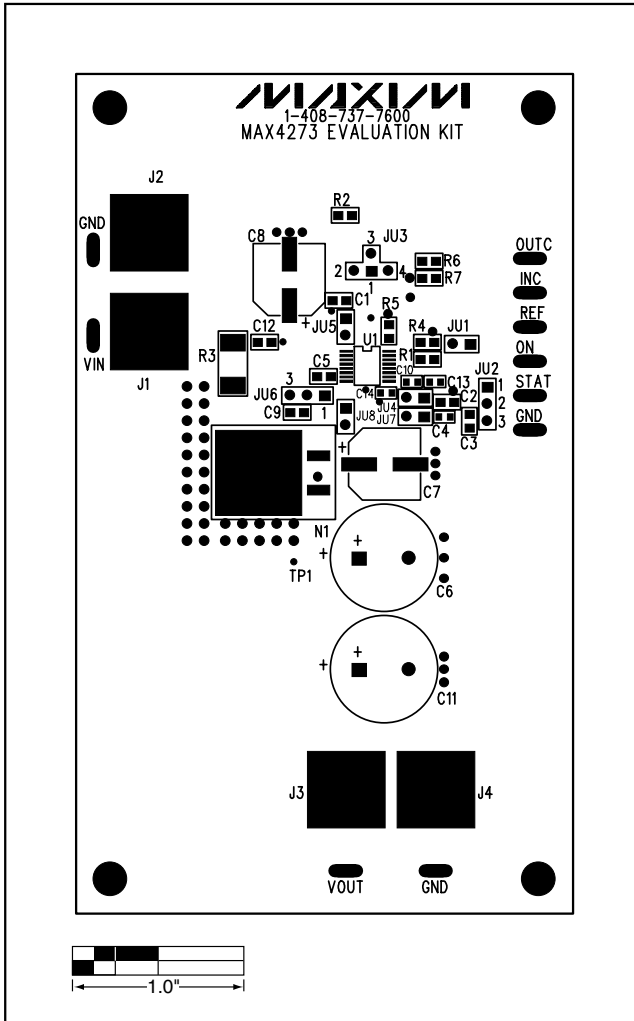

Figure 2. MAX4273 EV Kit Component Placement Guide—Top Silkscreen

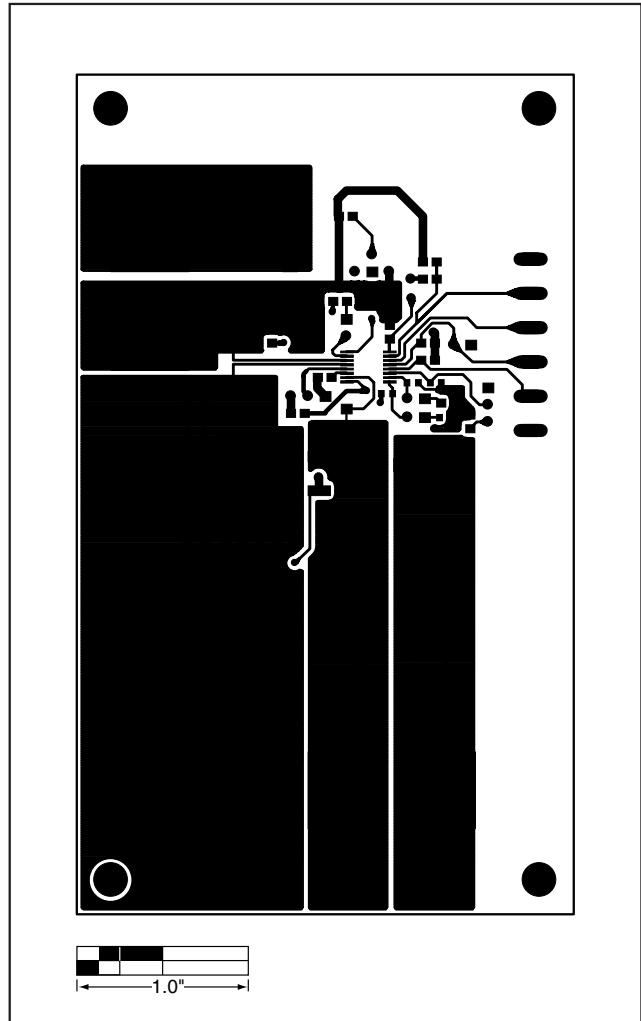

Figure 3. MAX4273 EV Kit PC Board Layout—Component Side

MAX4273 Evaluation Kit

Evaluates: MAX4273

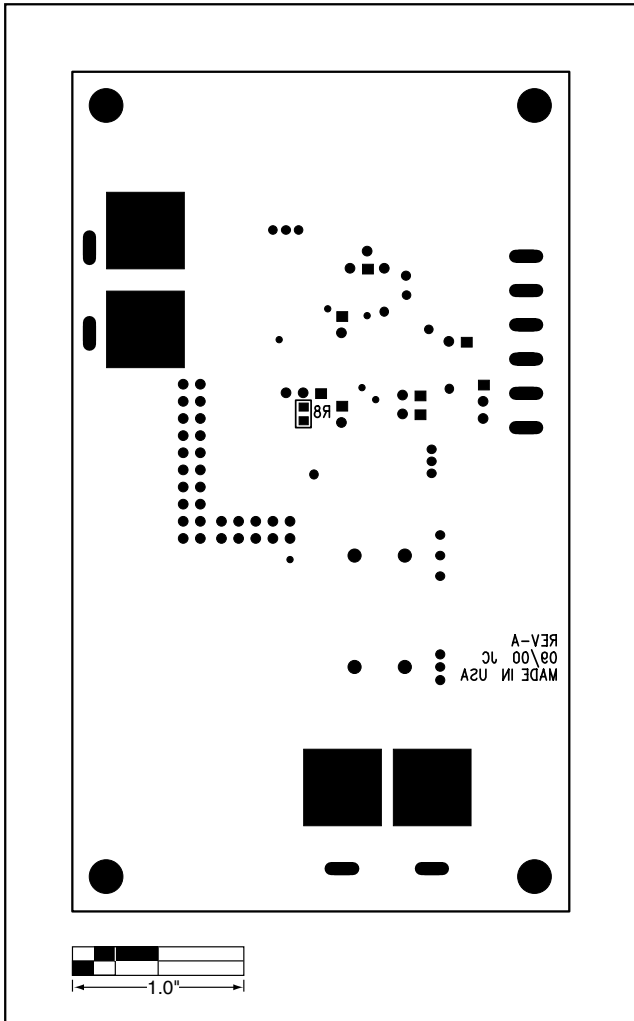

Figure 4. MAX4273 EV Kit Component Placement Guide—Bottom

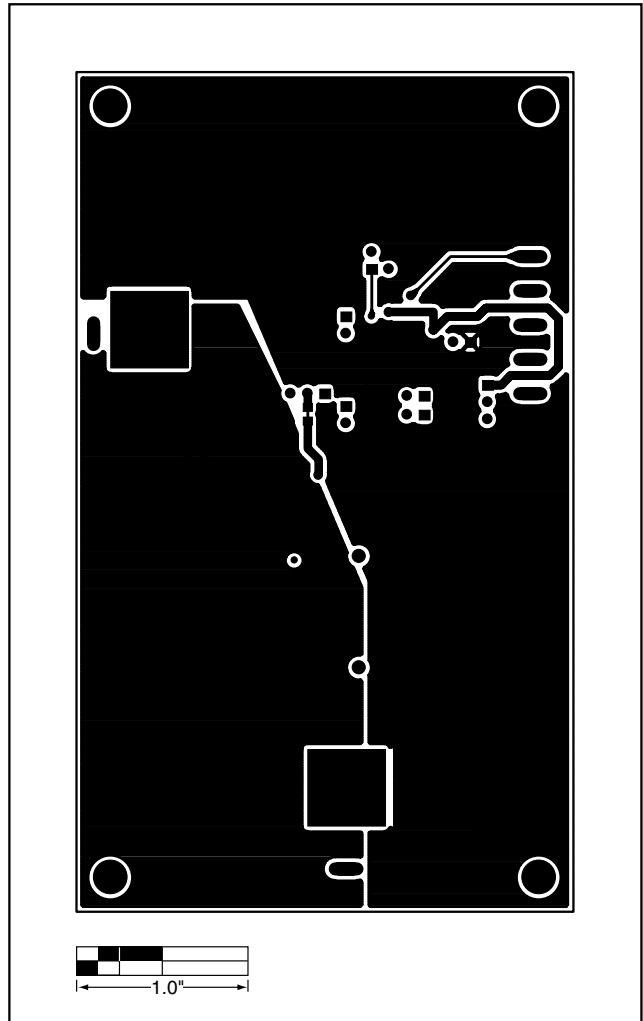

Figure 5. MAX4273 EV Kit PC Board Layout—Solder Side

Maxim cannot assume responsibility for use of any circuitry other than circuitry entirely embodied in a Maxim product. No circuit patent licenses are implied. Maxim reserves the right to change the circuitry and specifications without notice at any time.

8 **Maxim Integrated Products, 120 San Gabriel Drive, Sunnyvale, CA 94086 408-737-7600**